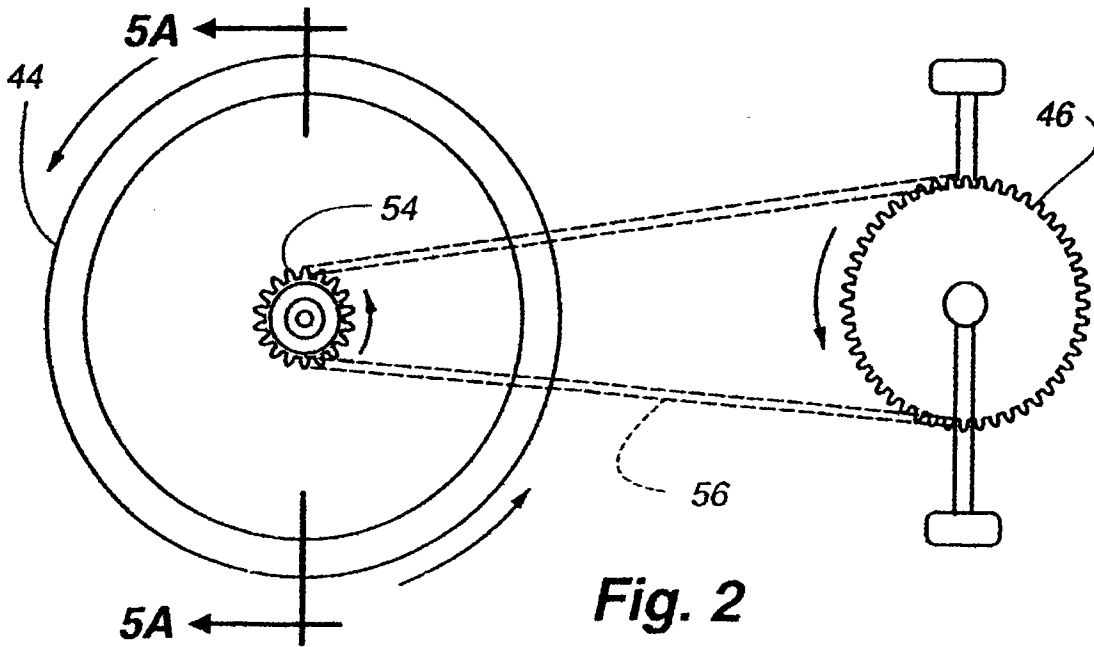


**Fig. 1**



**Fig. 2**

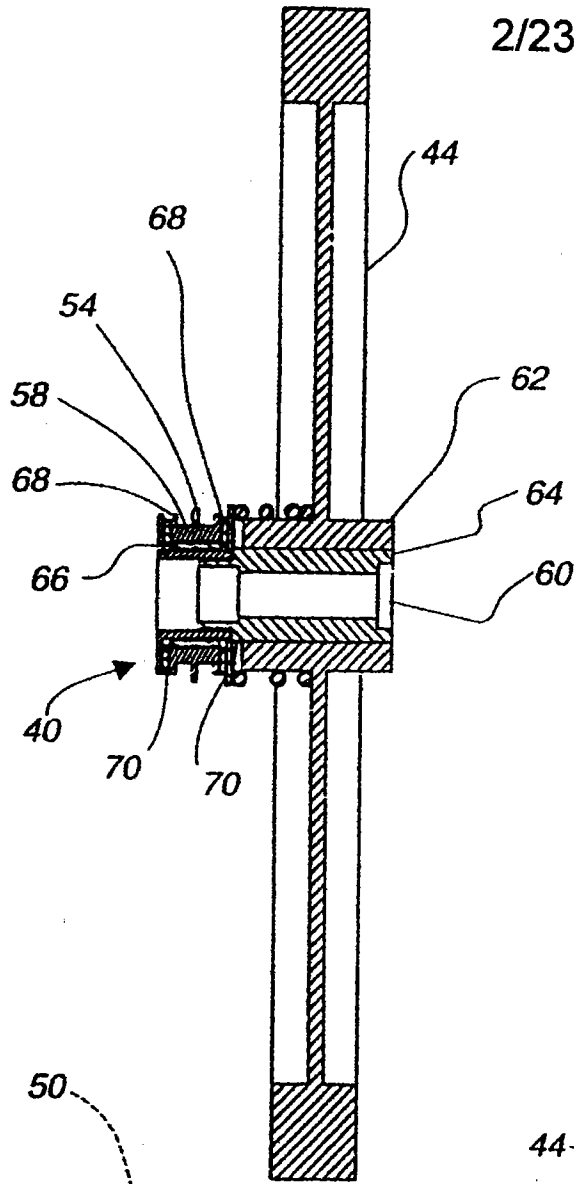
REPLACEMENT DRAWING SHEET

Entitled: "Free Wheel Clutch Mechanism For Bicycle Drive Train"

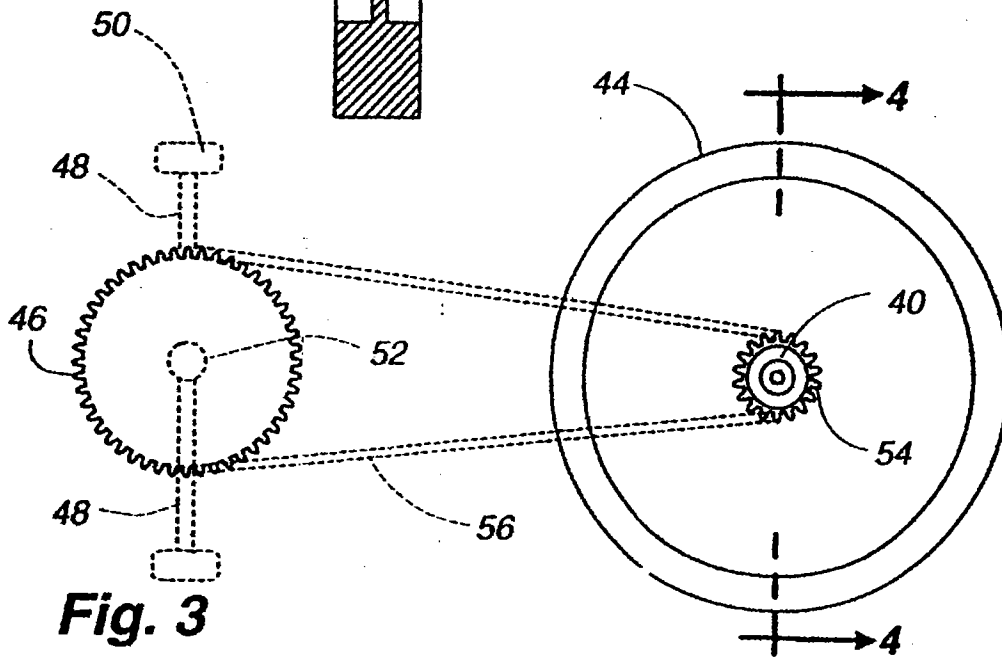
Application No.: 09/803,630; Filed: March 9, 2001;

Atty. Docket No.: 923/US/4; USPTO Customer No.: 20686

2/23



**Fig. 4**



**Fig. 3**

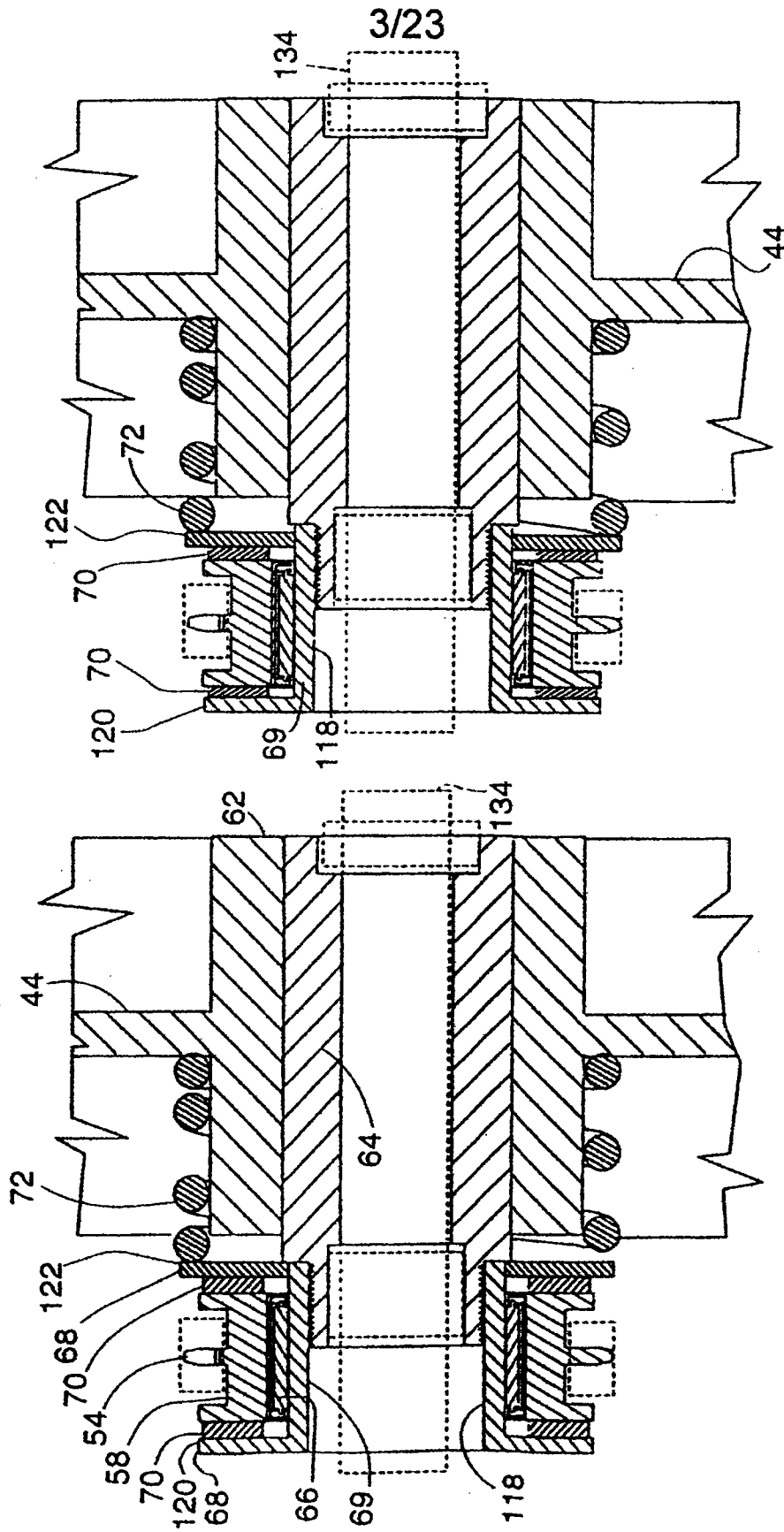
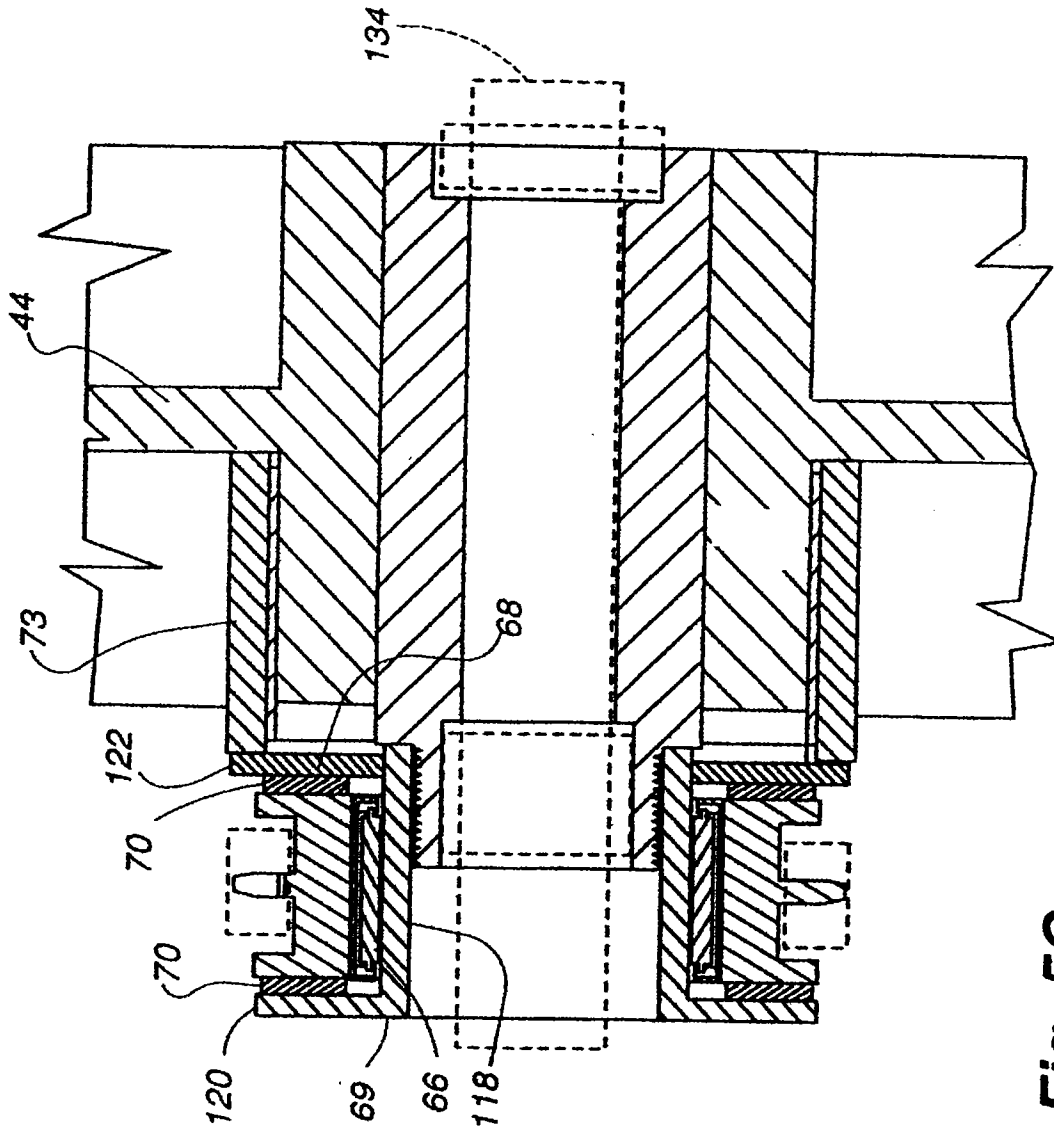


Fig. 5B

Fig. 5A

4/23



5/23

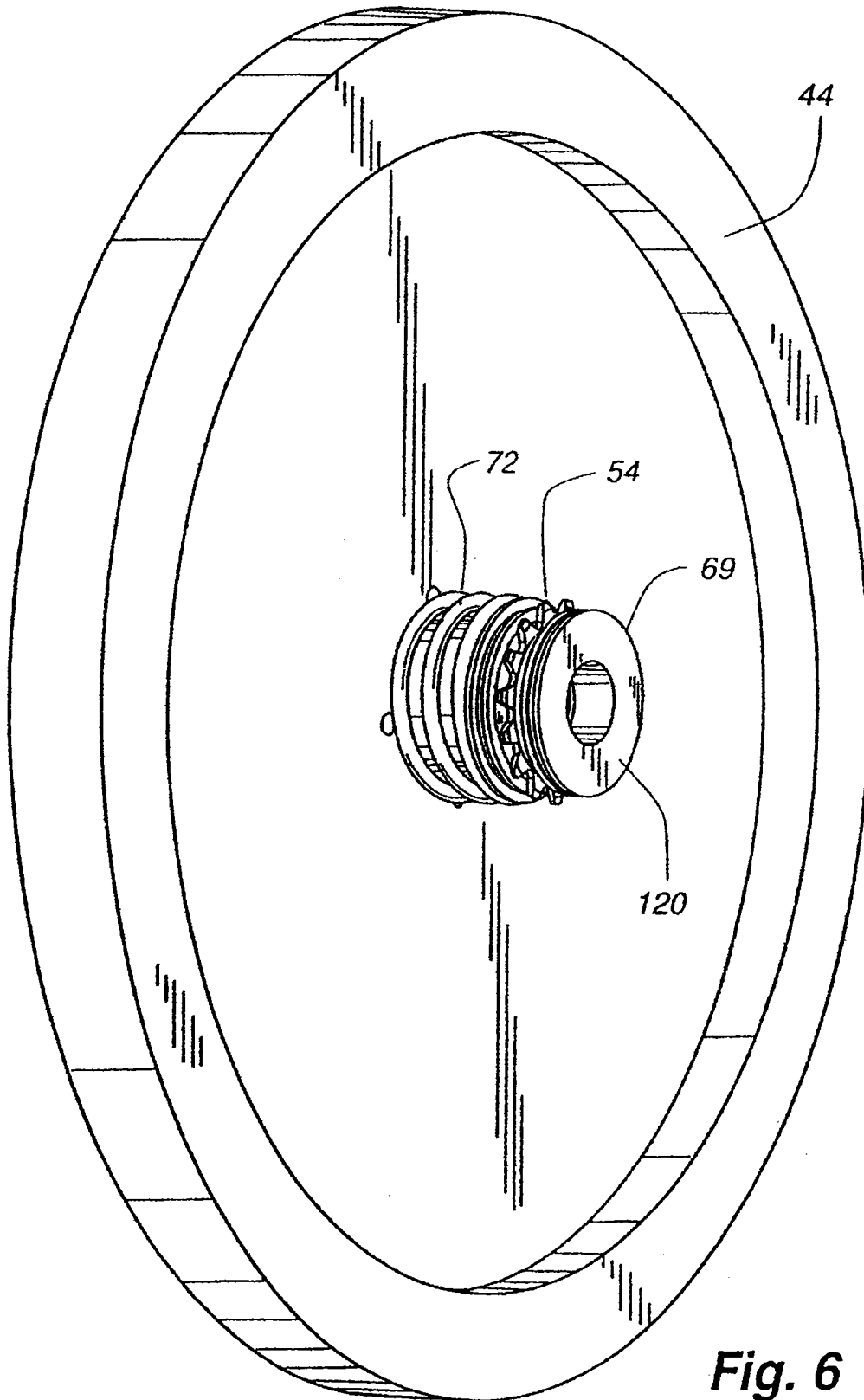


Fig. 6

6/23

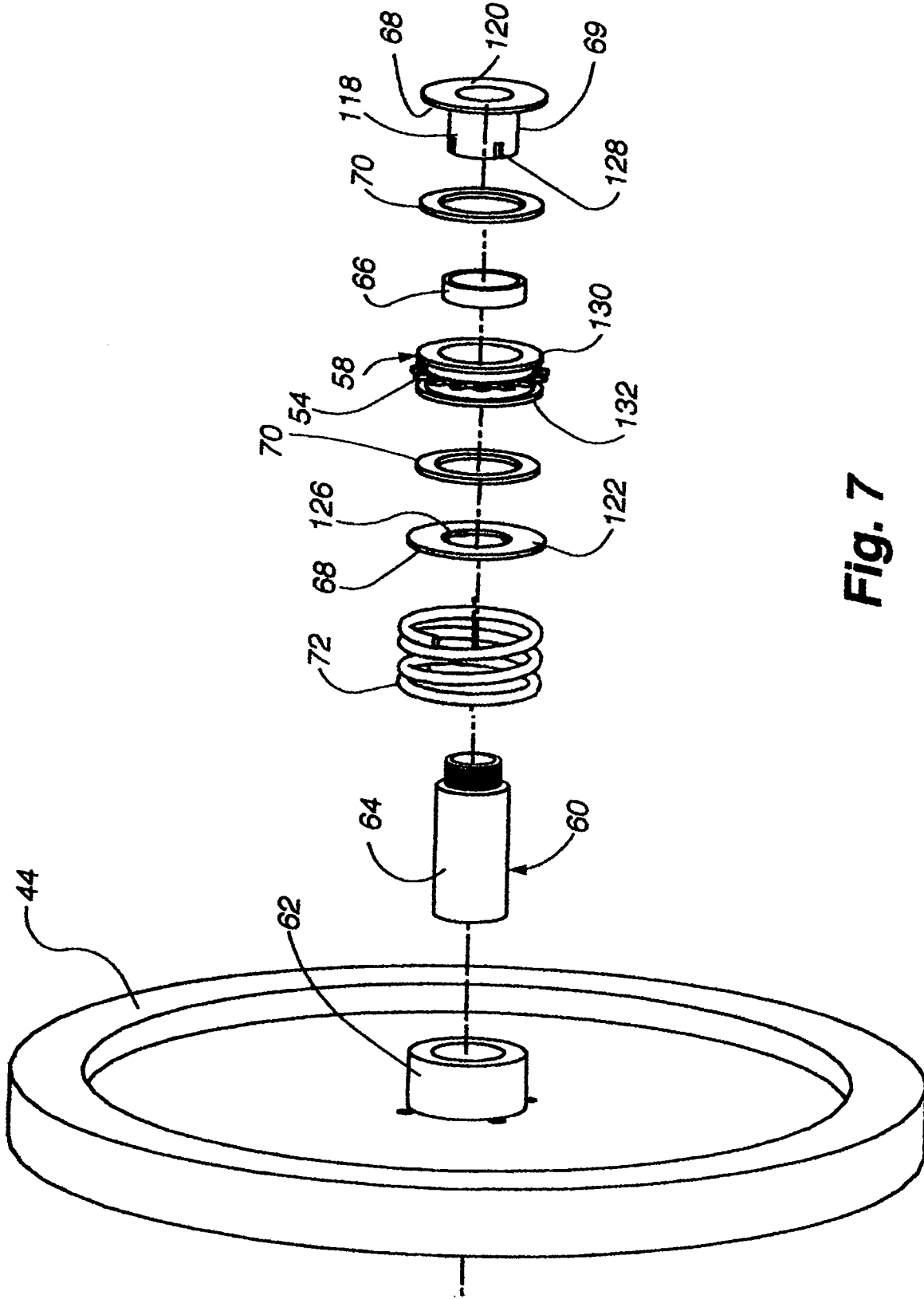
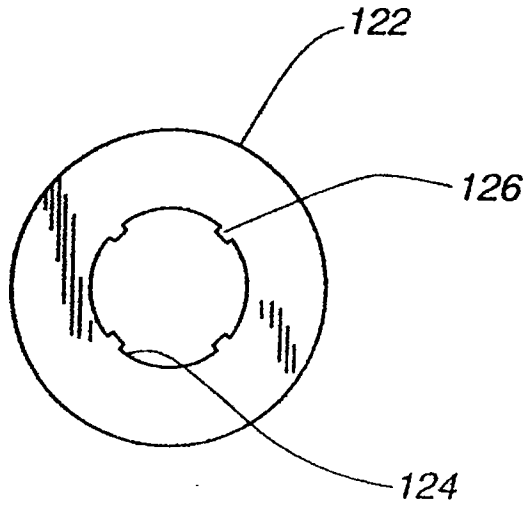
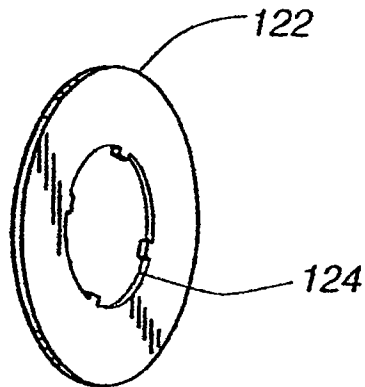


Fig. 7

7/23

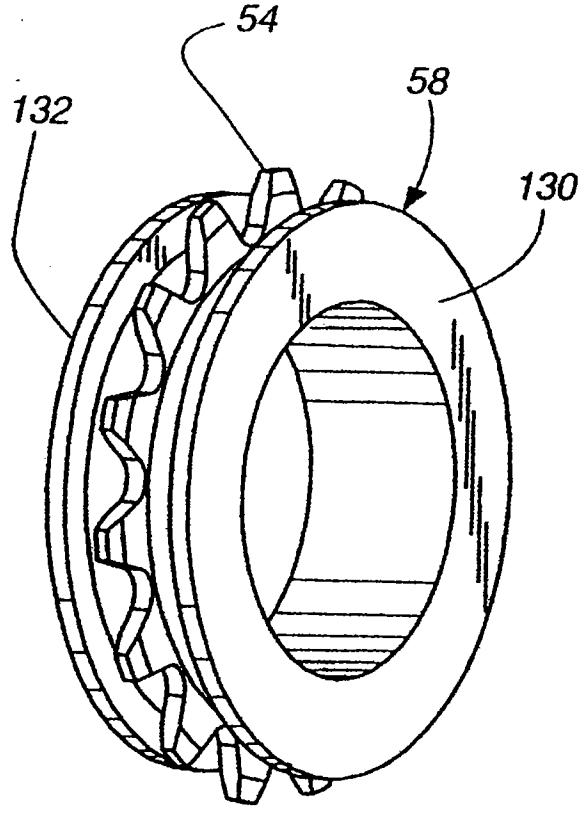
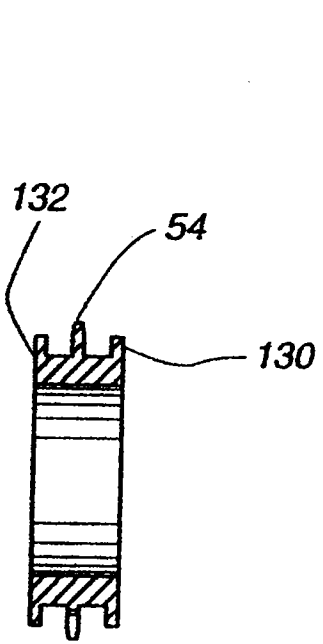
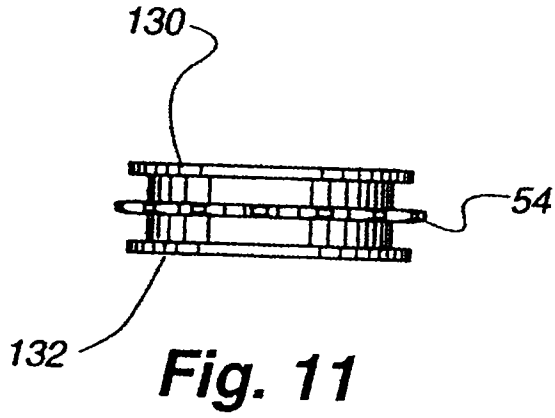
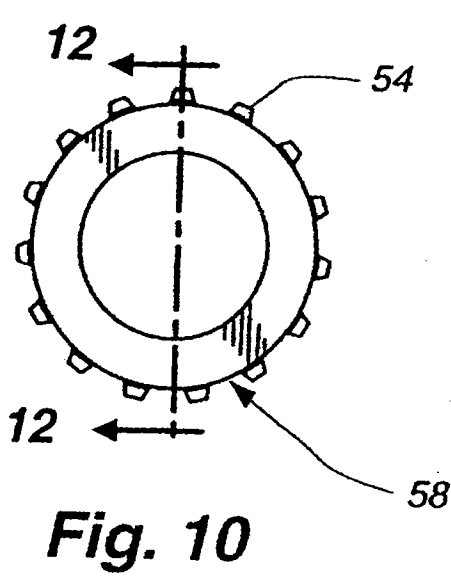


**Fig. 8**



**Fig. 9**

8/23

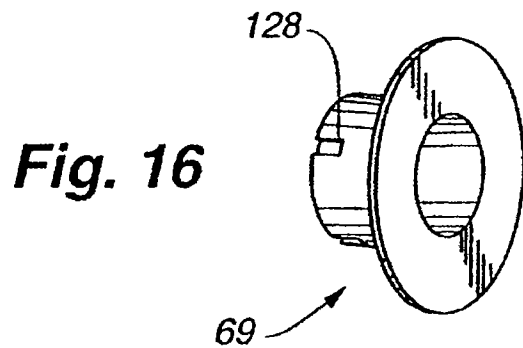
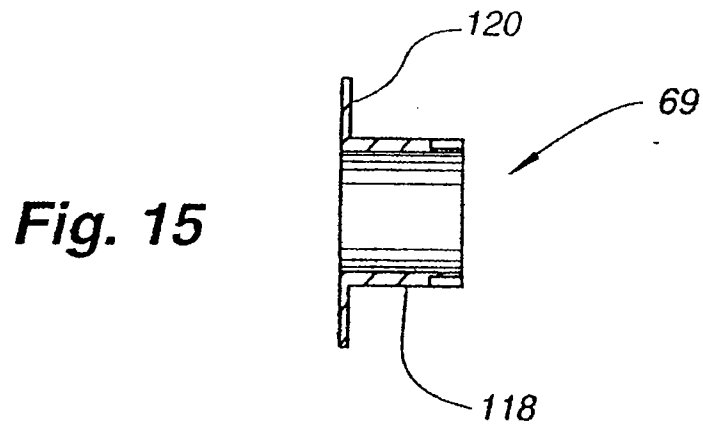
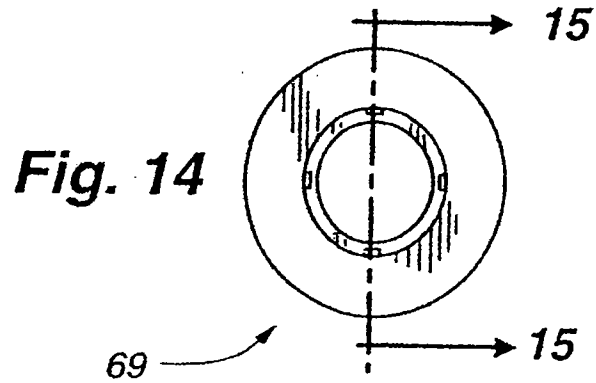


**Fig. 12**

**Fig. 13**



9/23



10/23

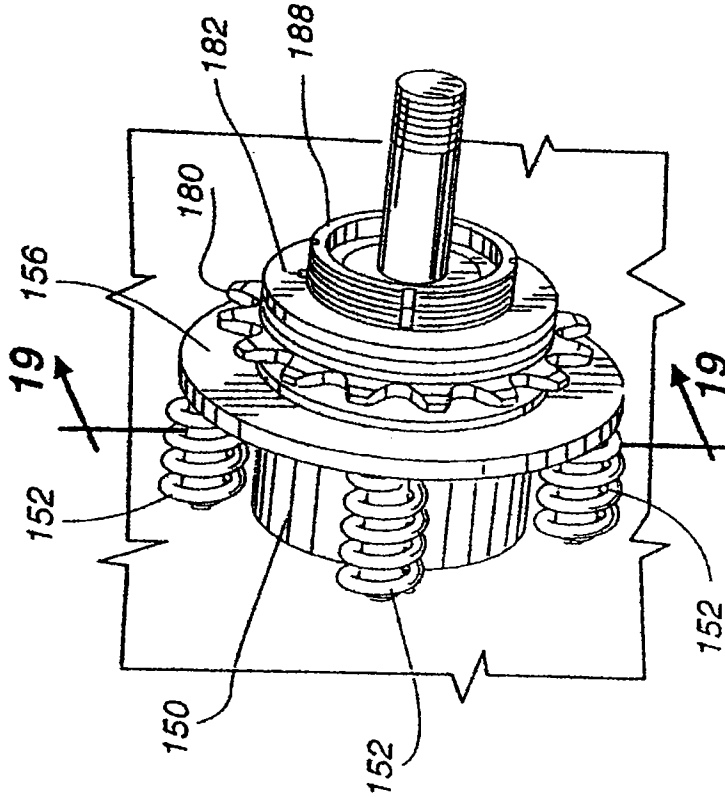


Fig. 18

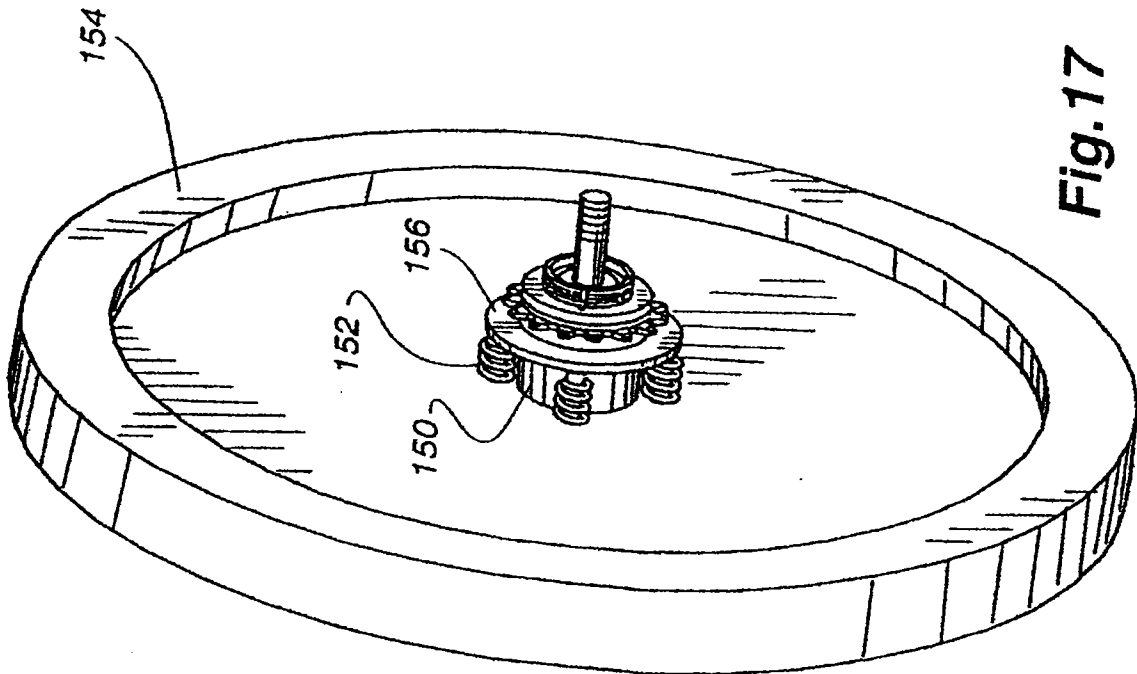


Fig. 17

11/23

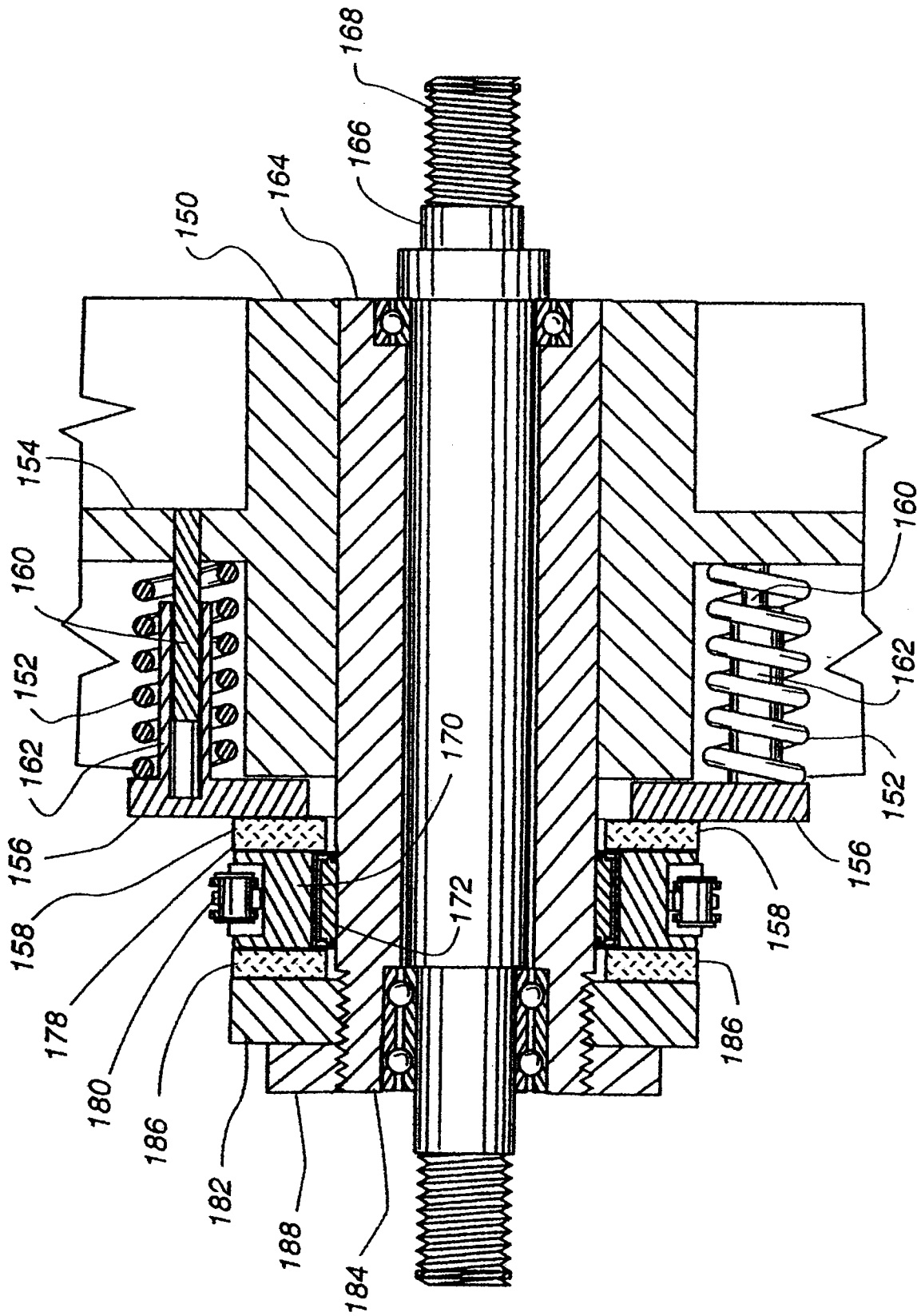


Fig. 19

12/23

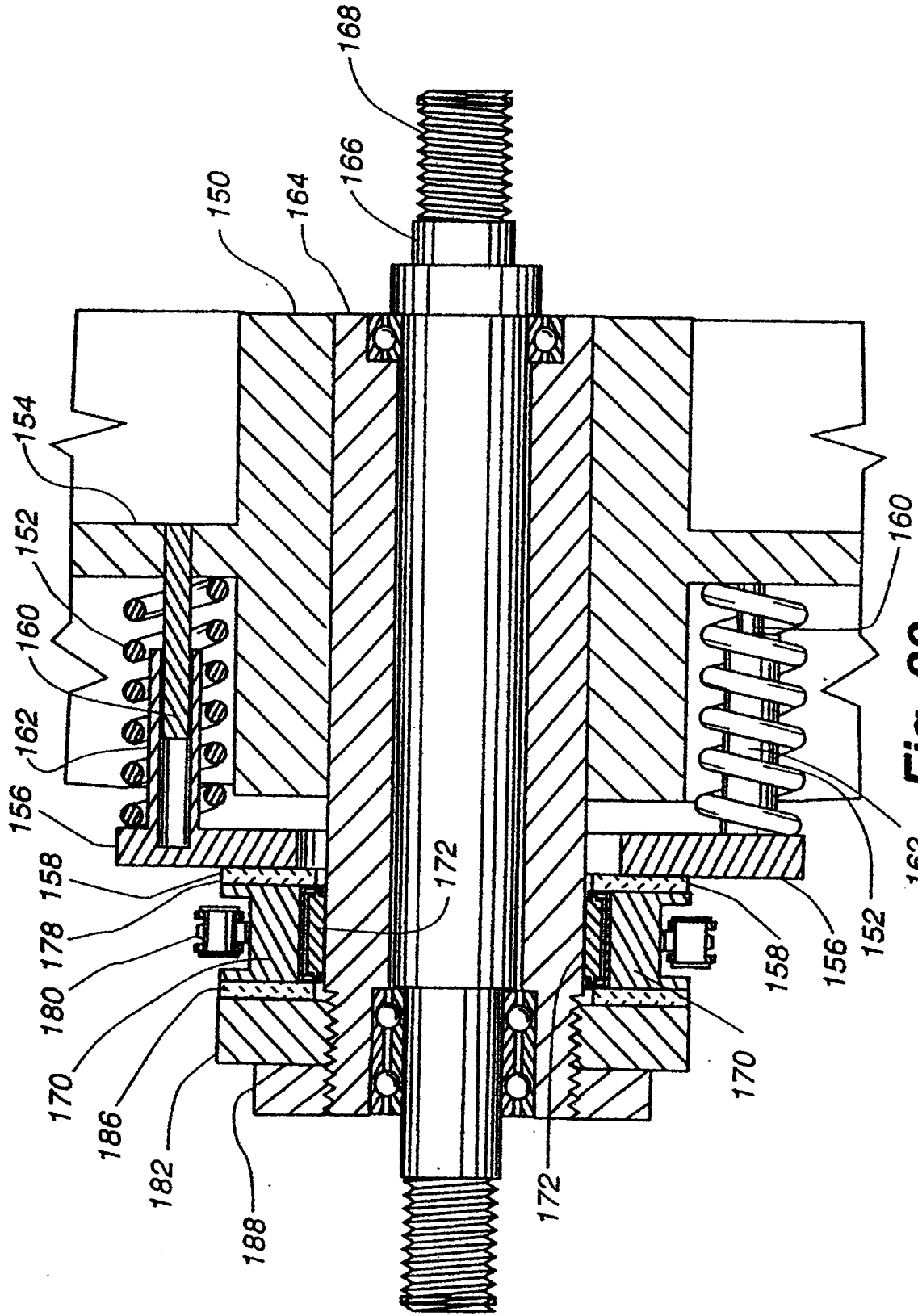
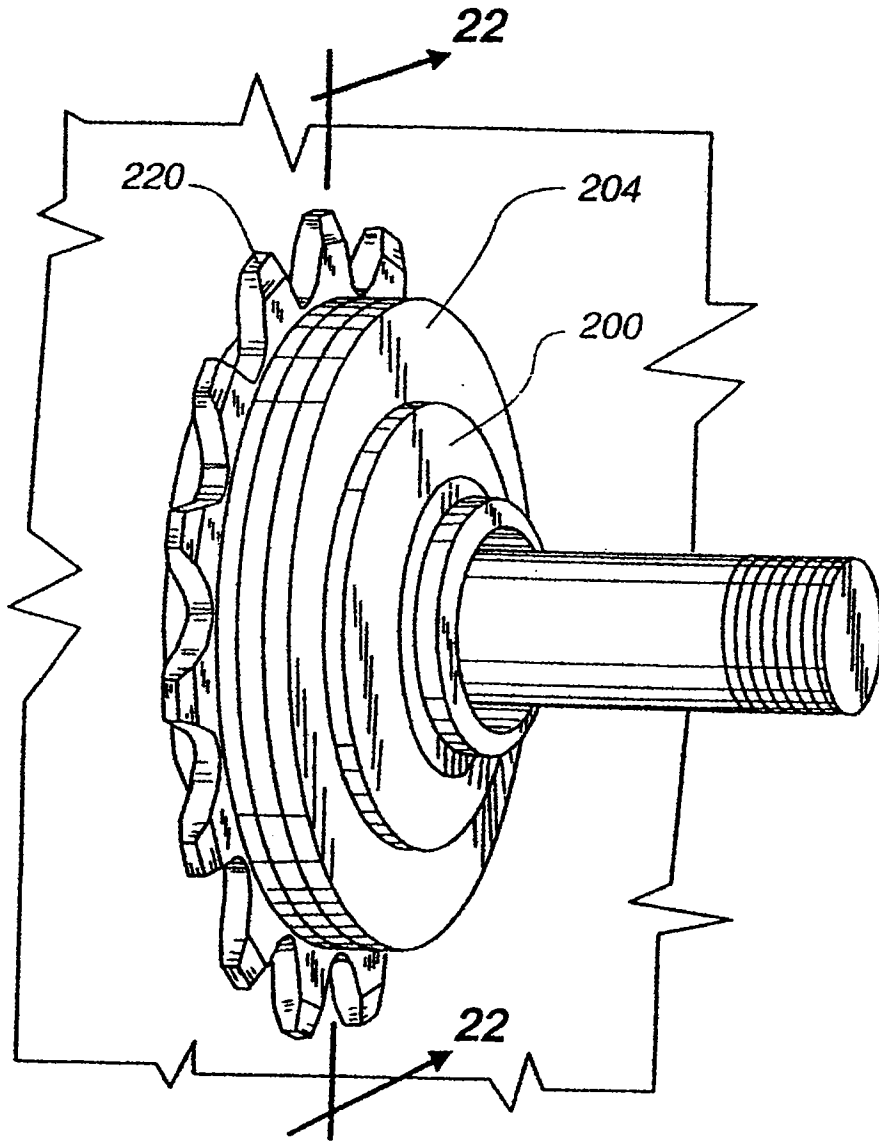


Fig. 20

162

13/23



**Fig. 21**

14/23

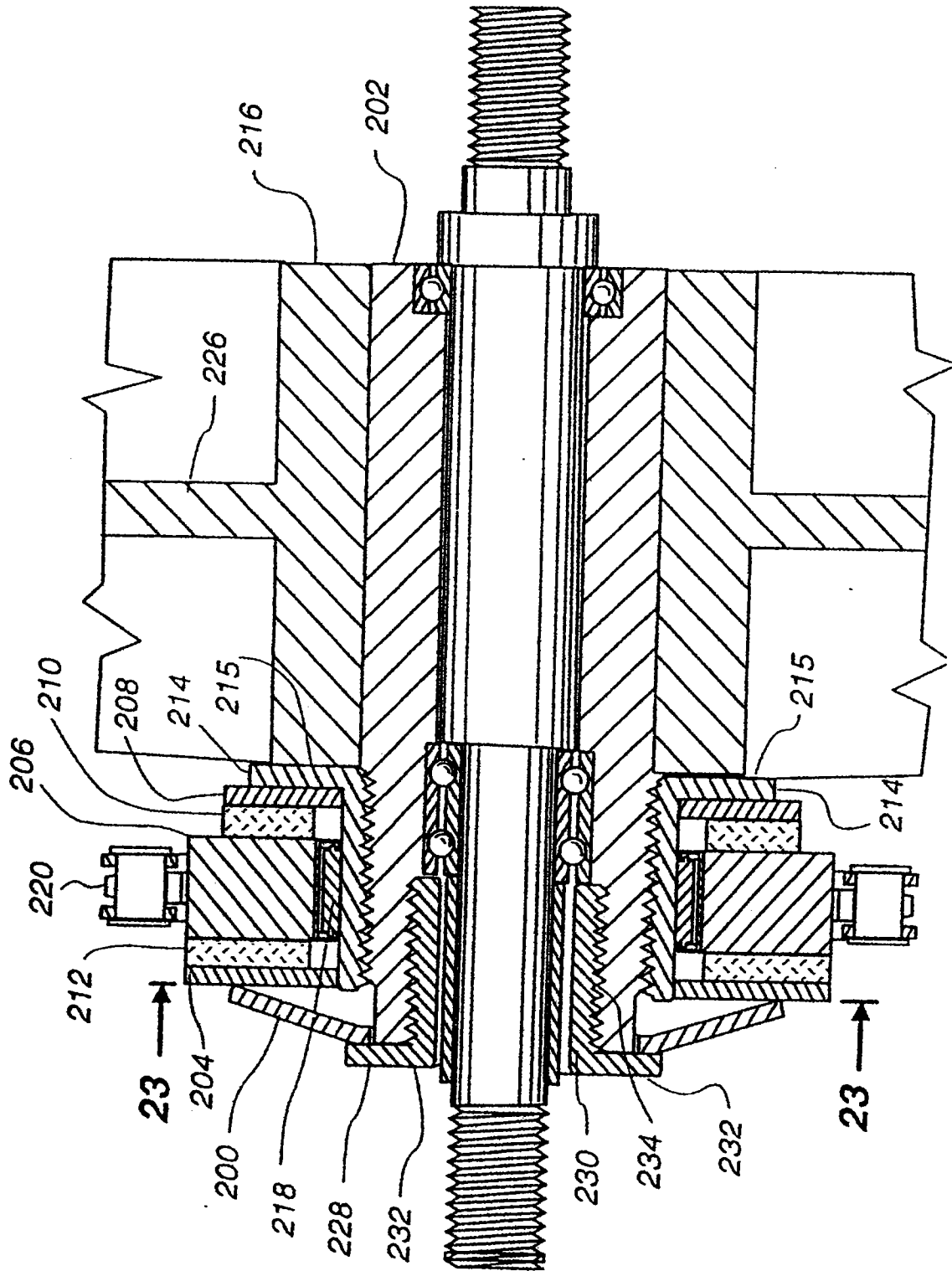


Fig. 22

15/23

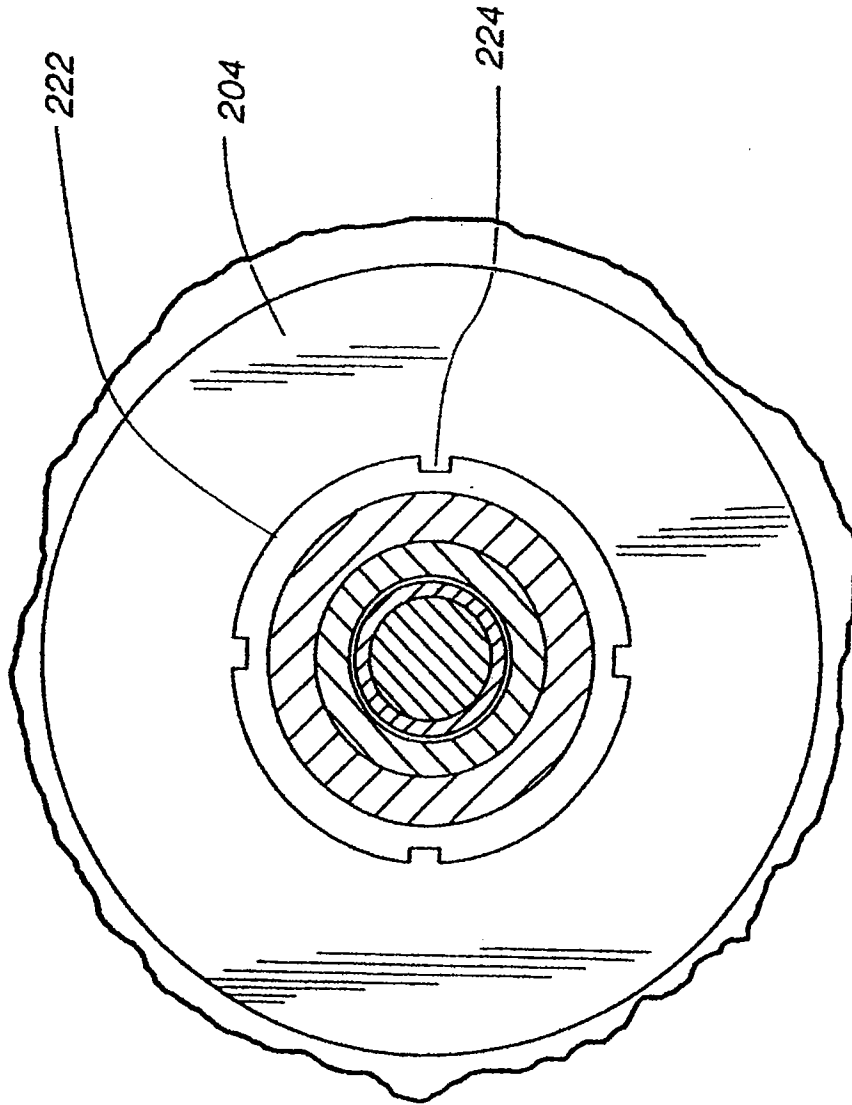


Fig. 23

16/23

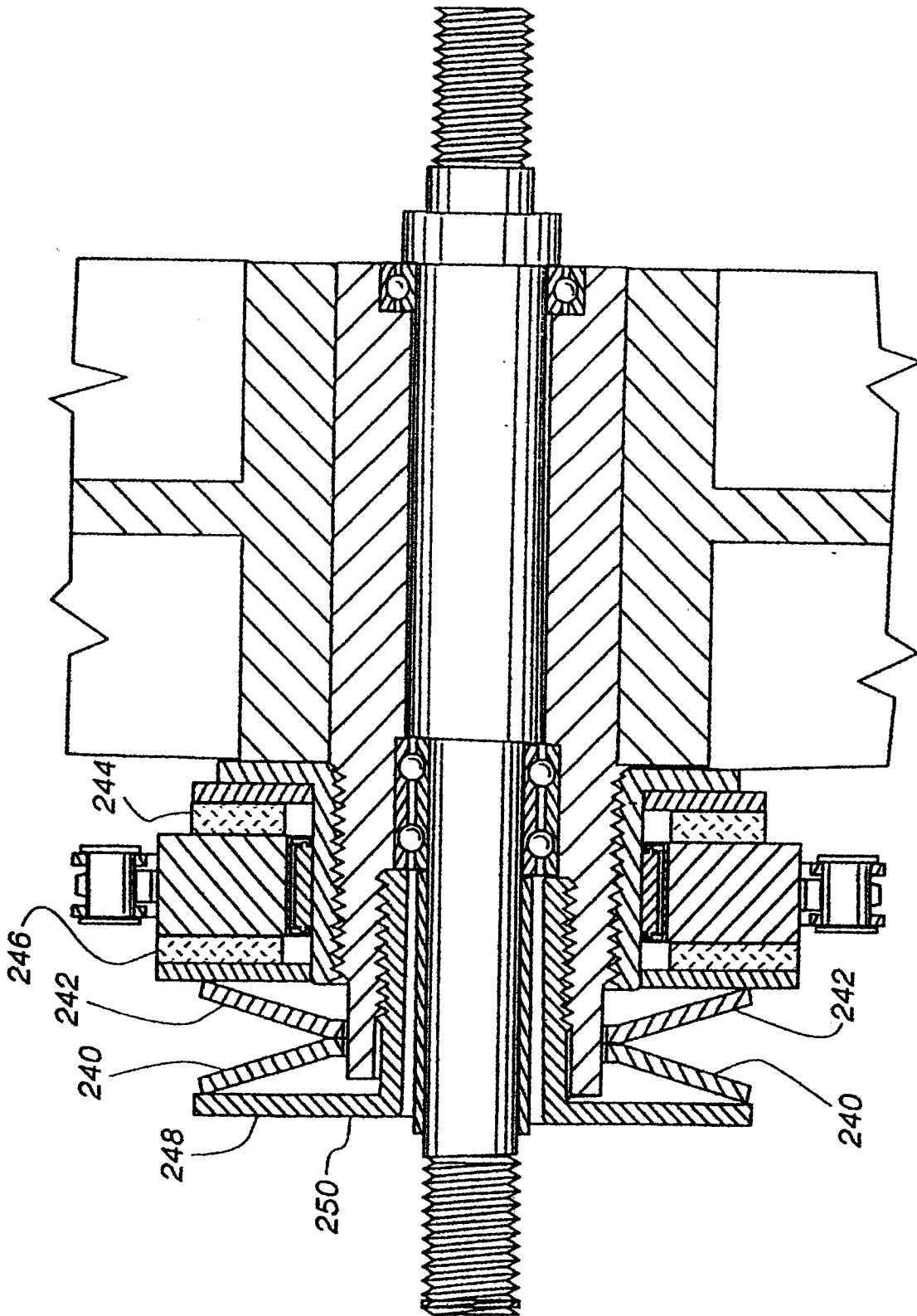


Fig. 24



17/23

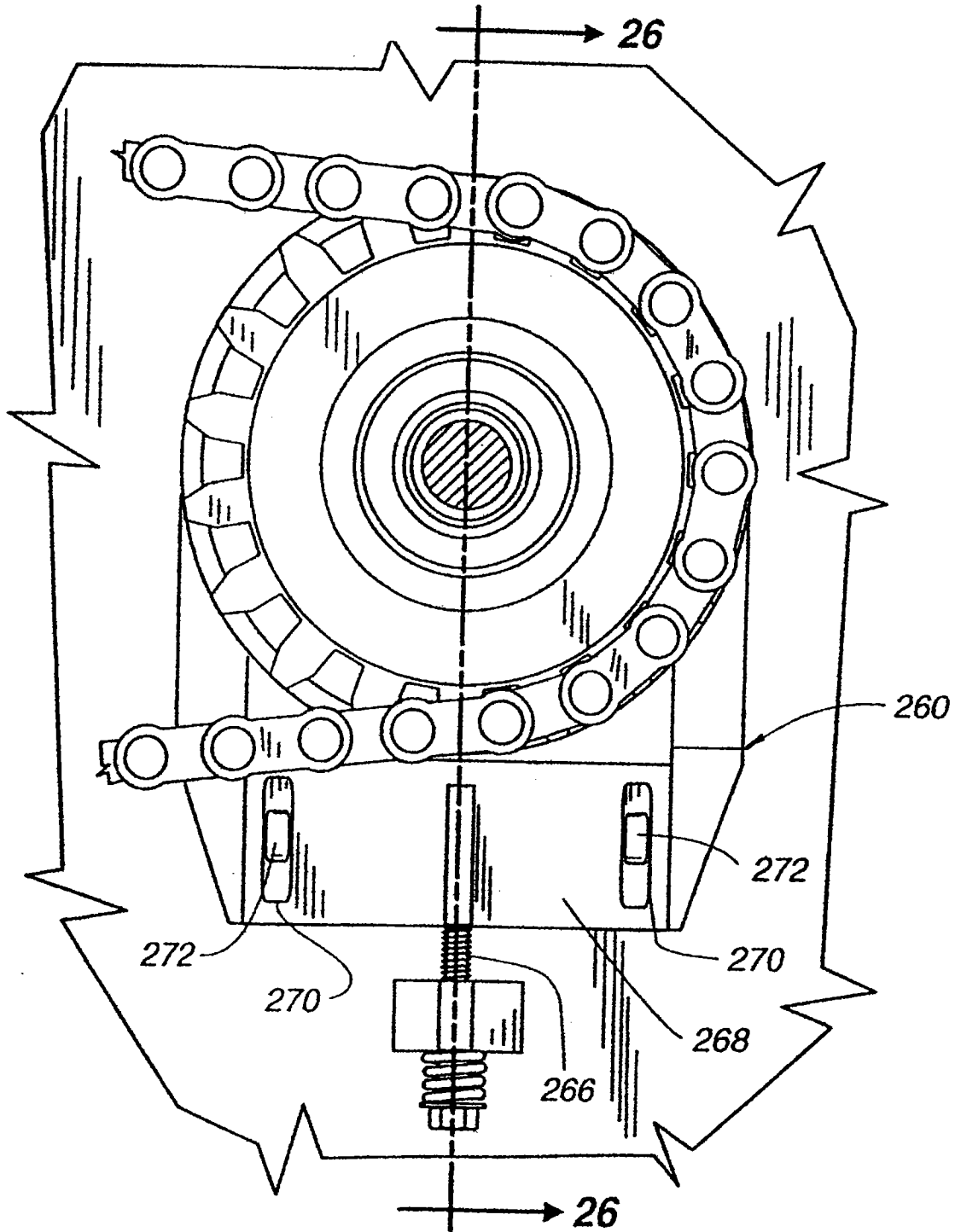
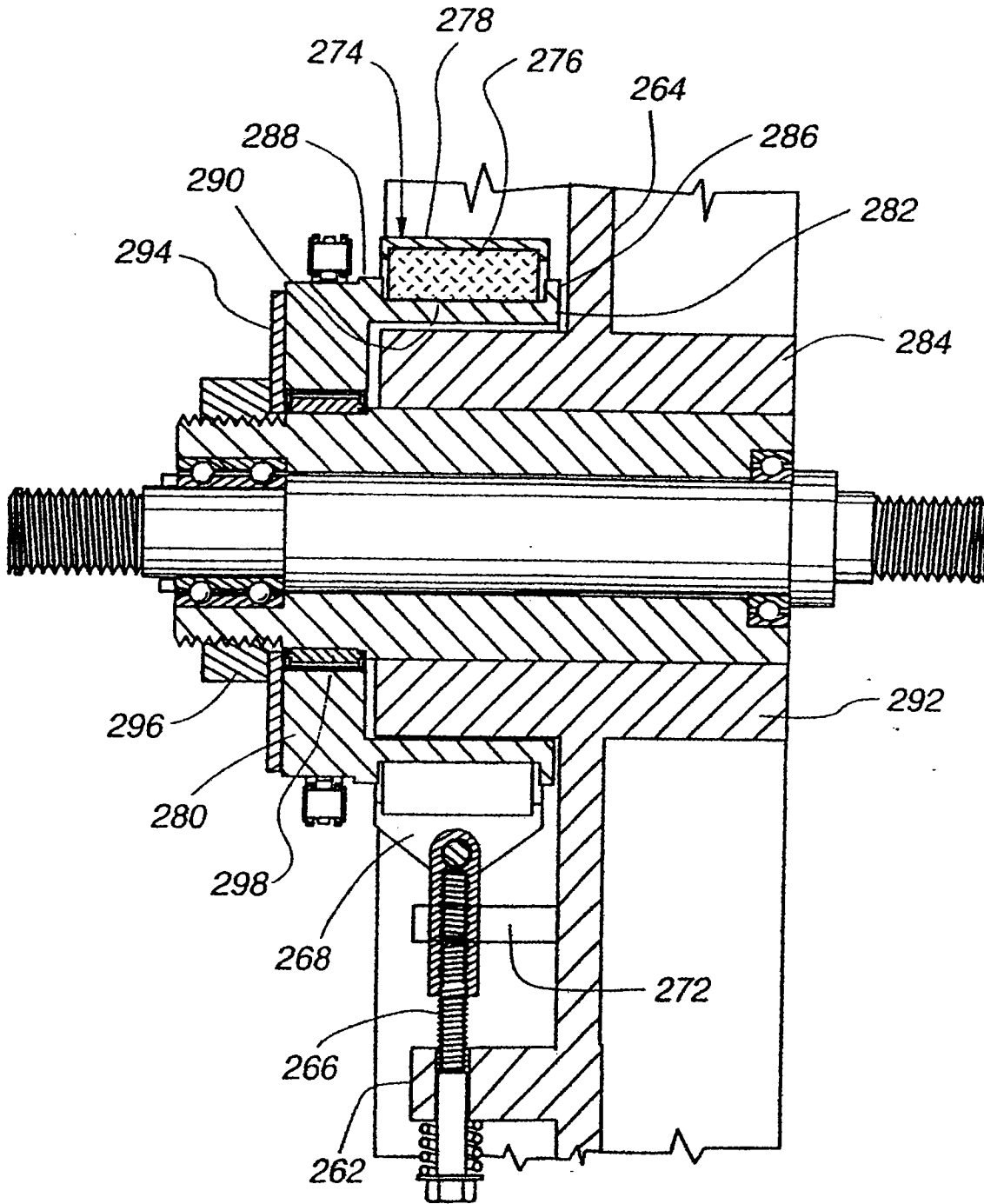


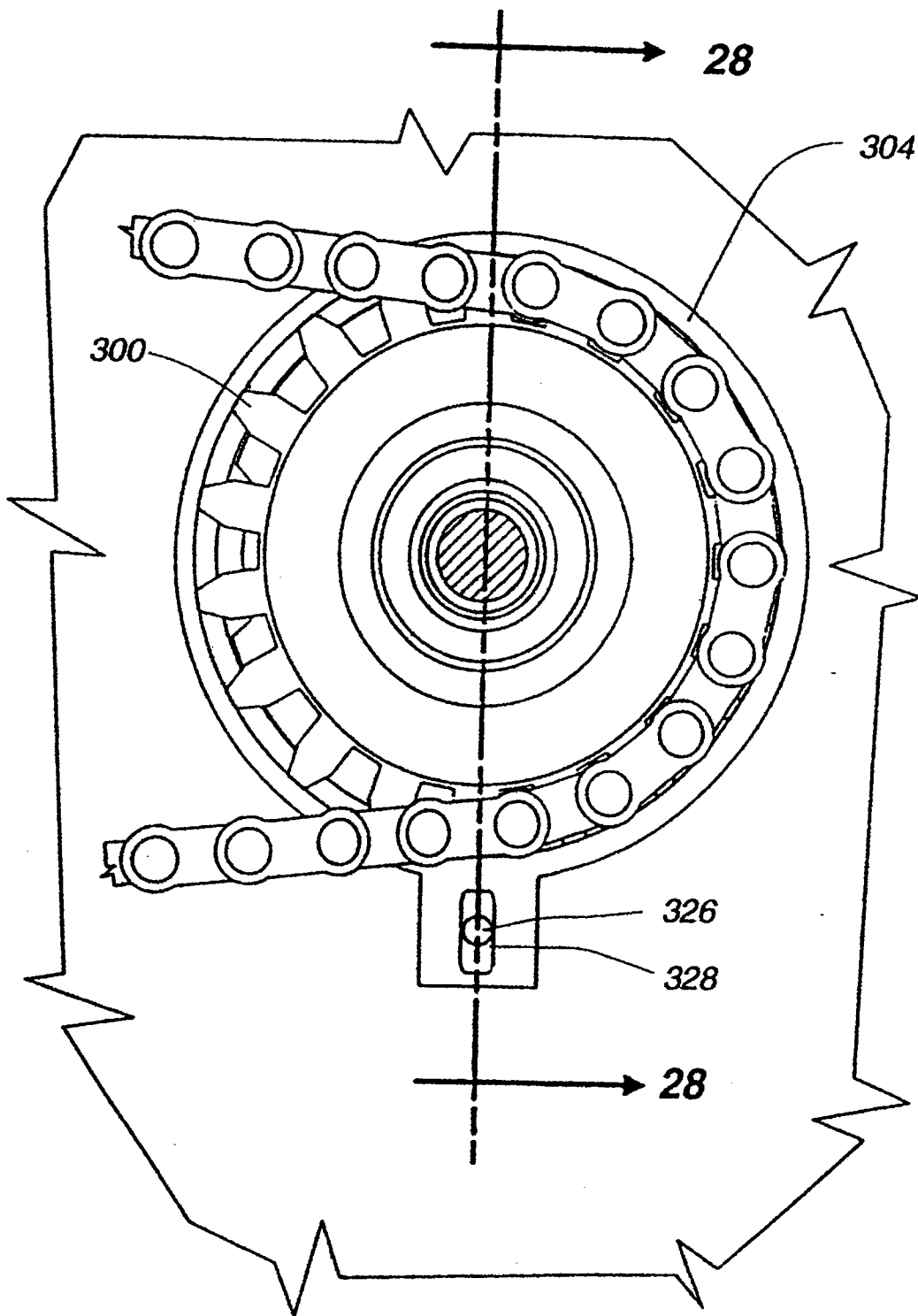
Fig. 25

18/23

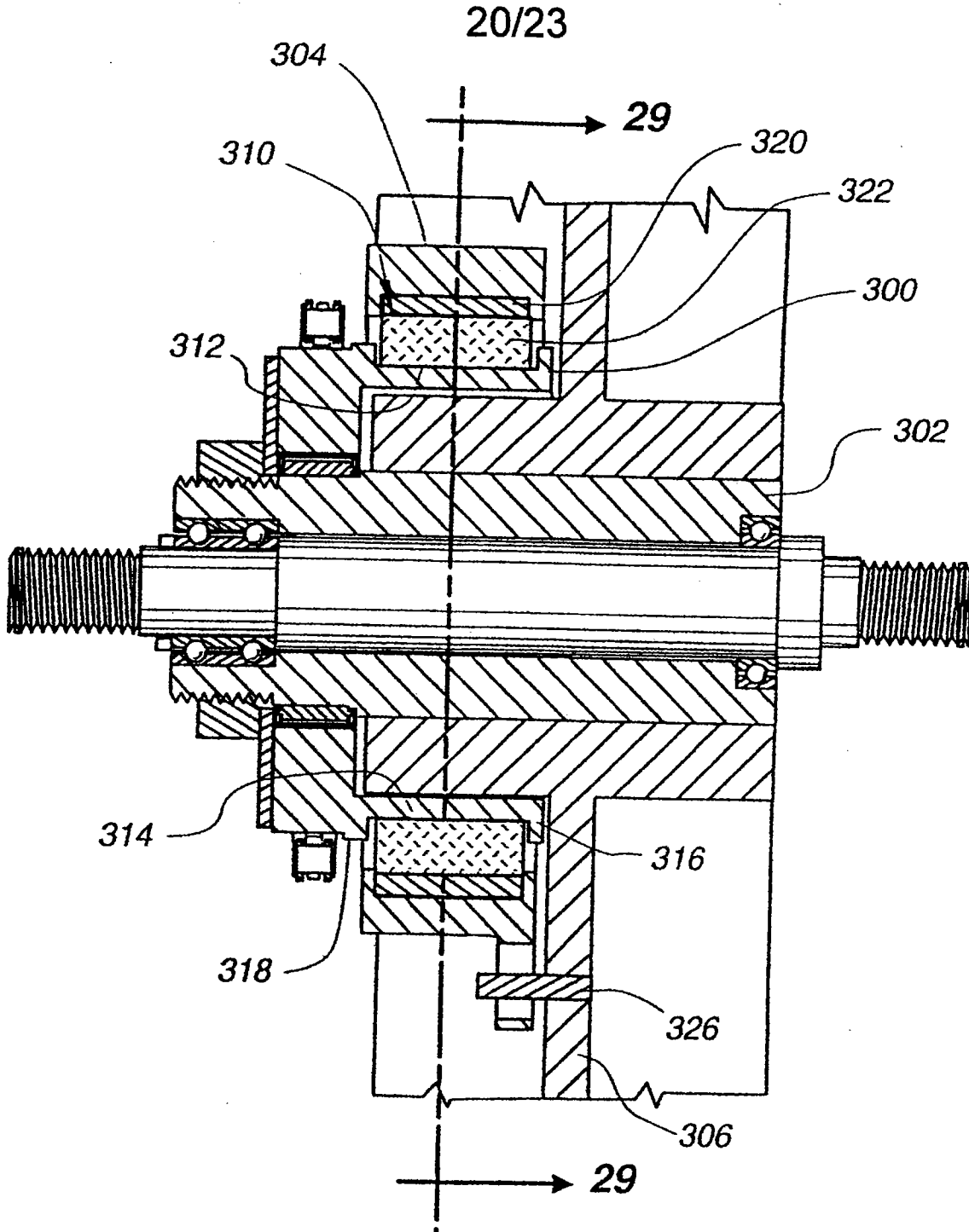


**Fig. 26**

19/23

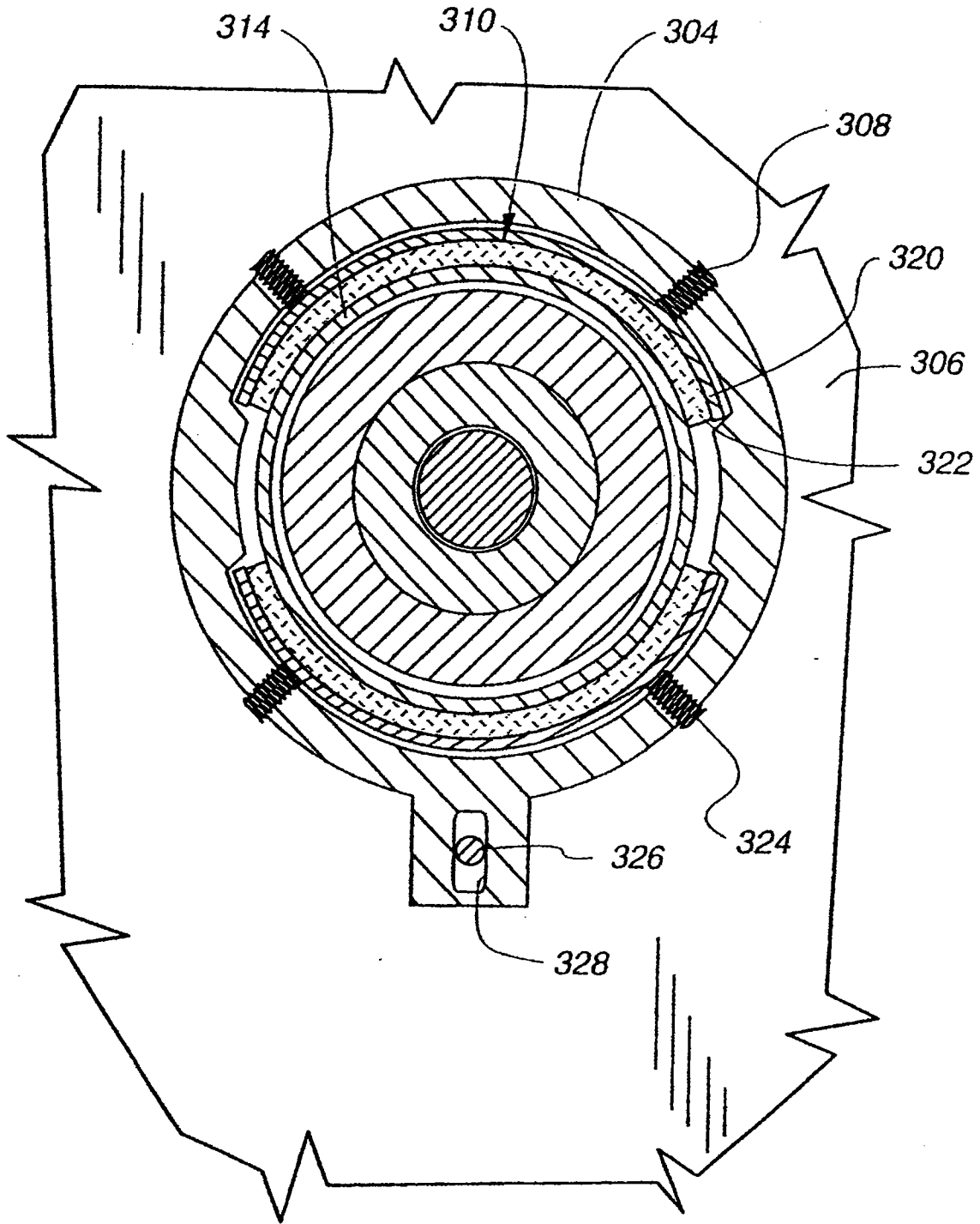


**Fig. 27**



**Fig. 28**

21/23



**Fig. 29**

22/23

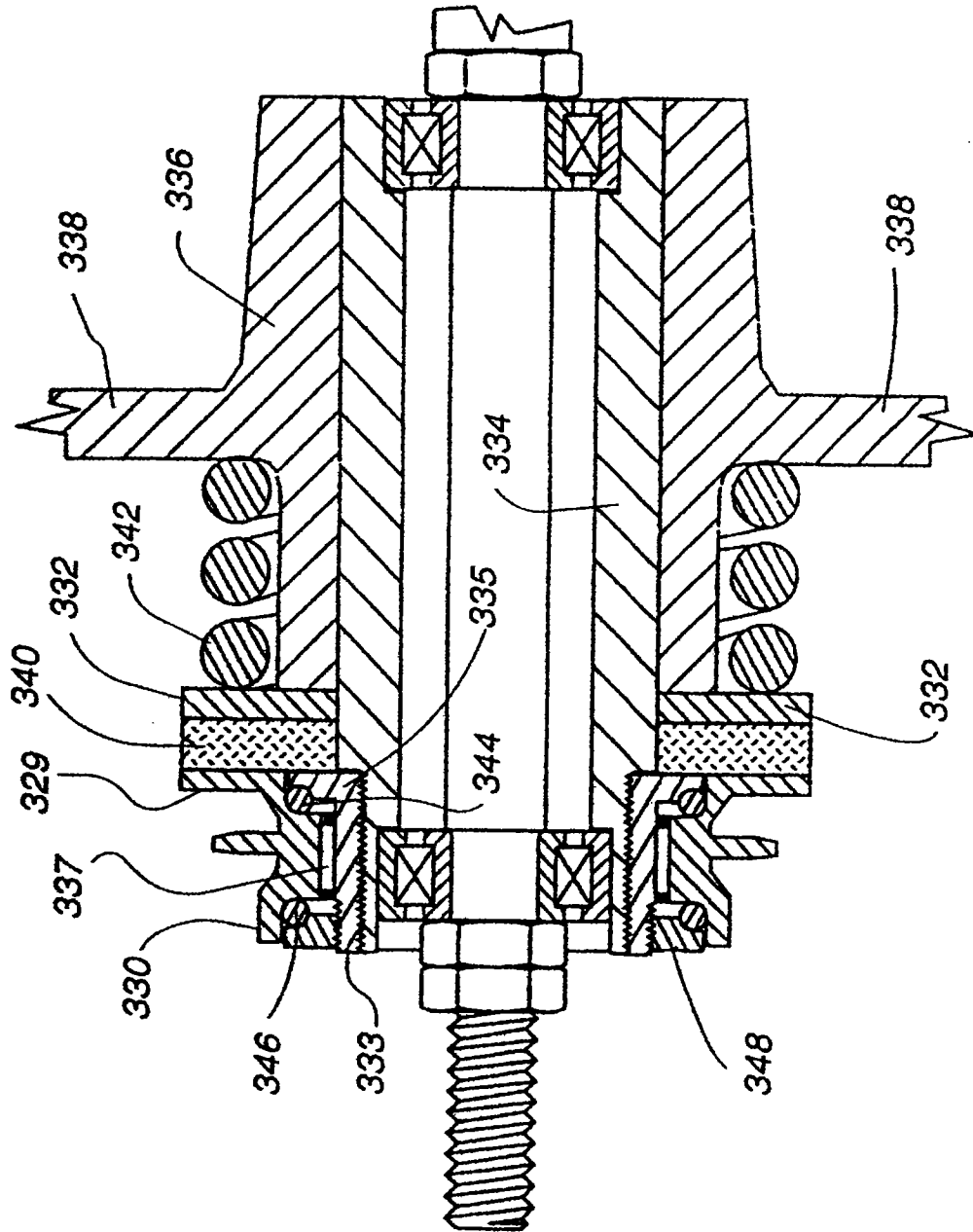
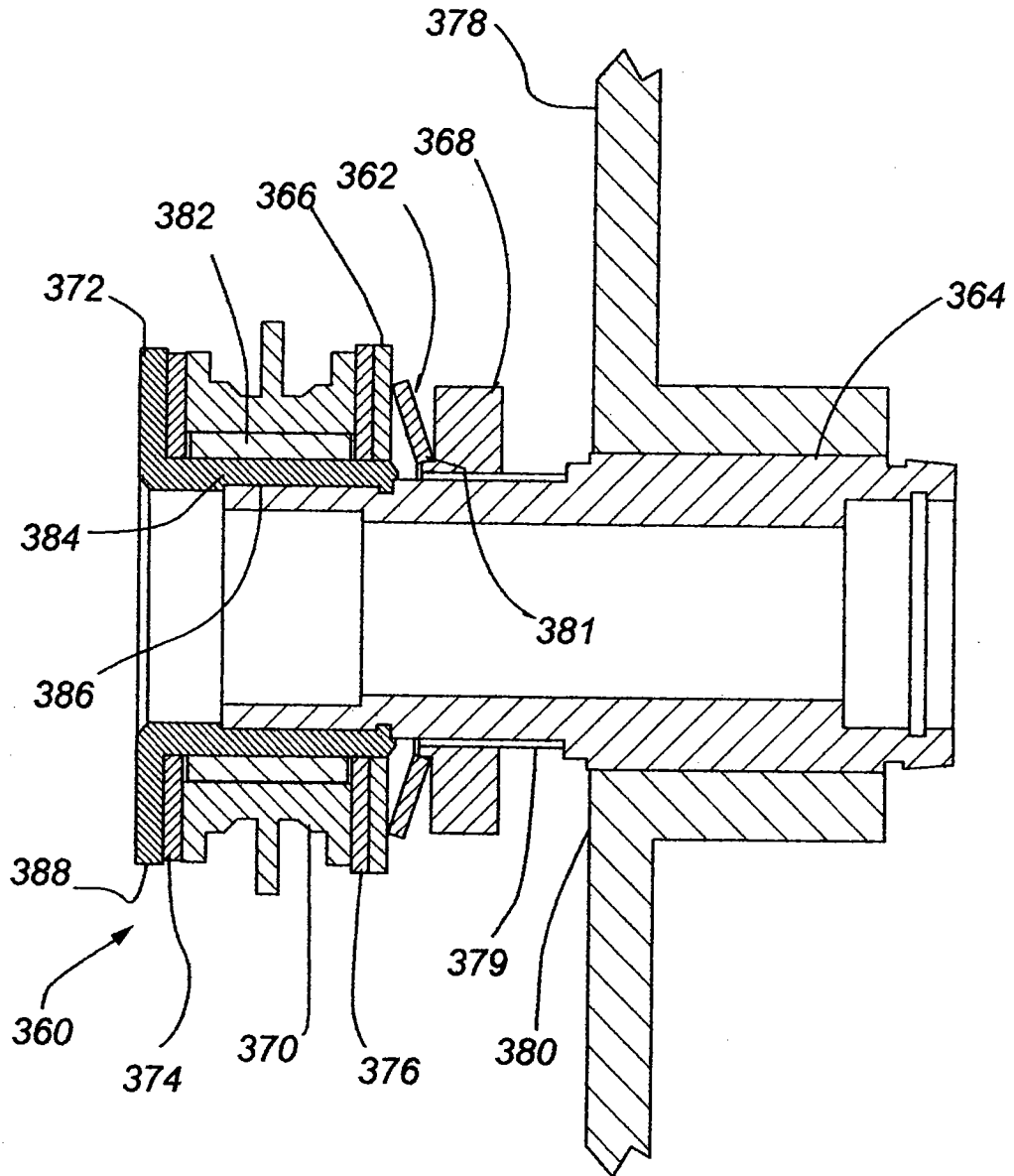


Fig.30

23/23



**Fig. 31**